

# Model PMD420/PMD430

OWNER'S MANUAL

STEREO  
CASSETTE RECORDER



**marantz®**

# MODEL PMD420

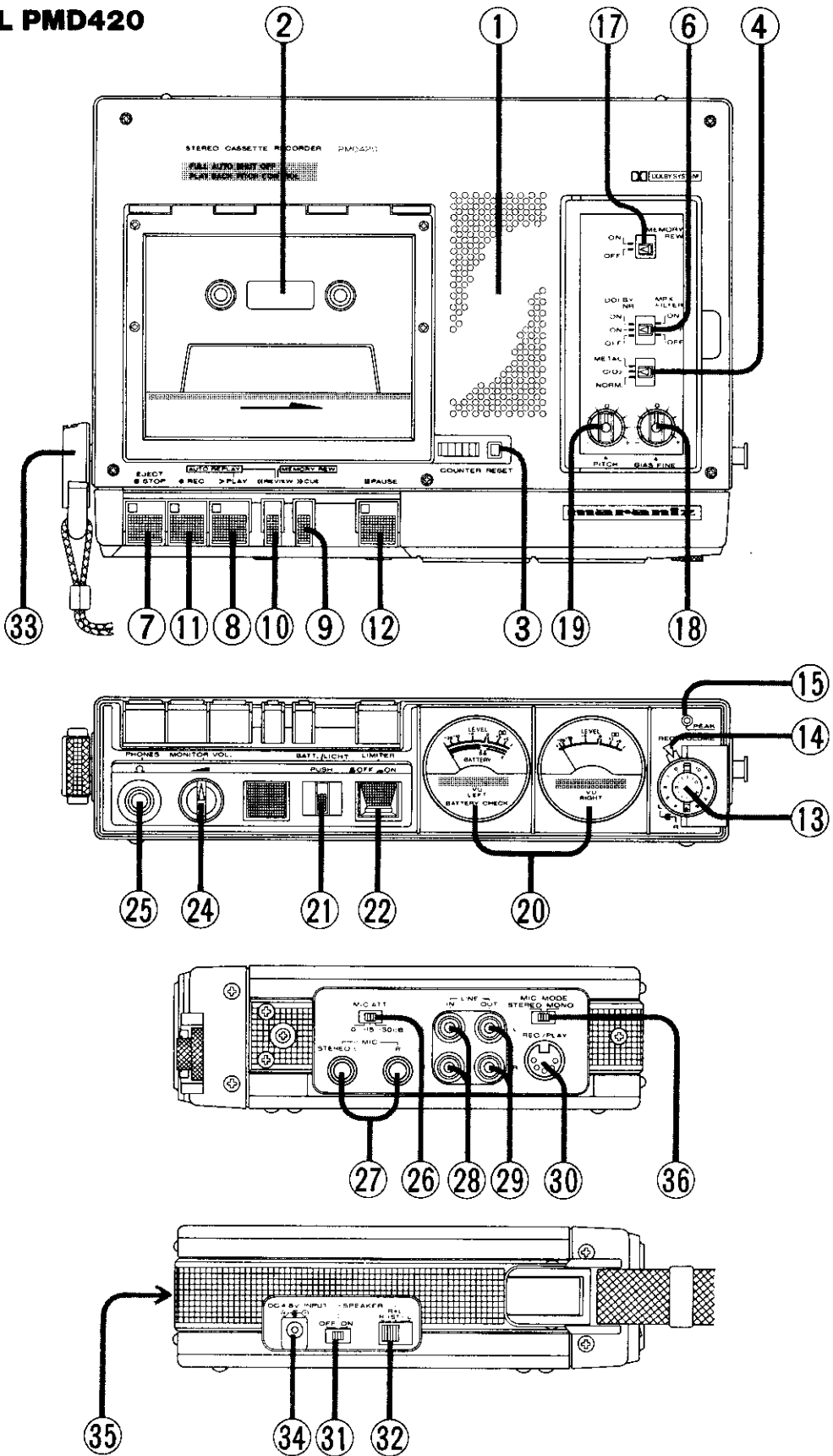

Figure 1.

# MODEL PMD430

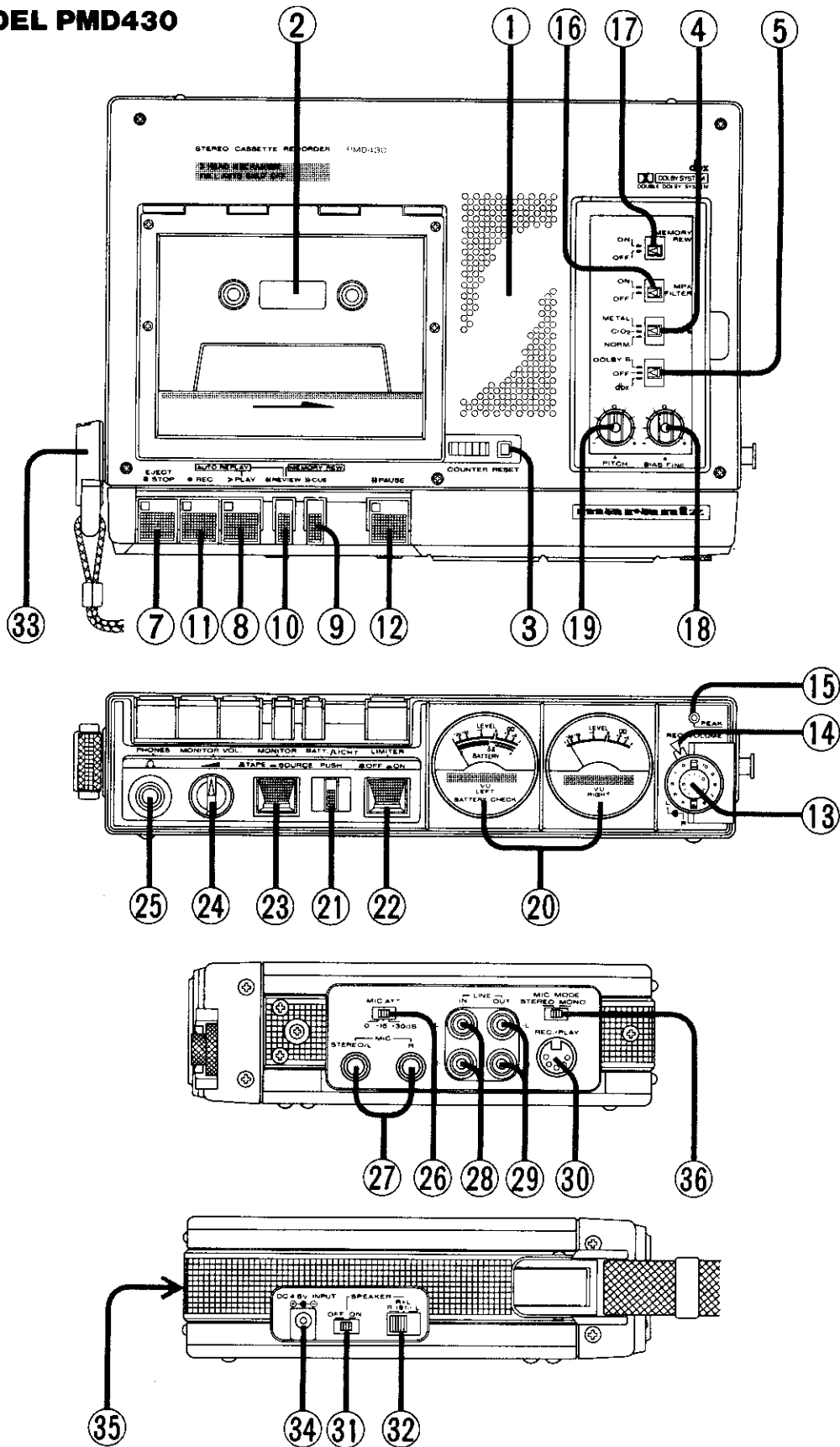

Figure 2.

## FOREWARD

To obtain maximum performance and enjoyment from your Stereo Cassette Recorder, please study these instructions carefully. Installing and operating your unit is not complicated, but the flexibility provided by its numerous operating features merit your becoming familiar with its controls and connections. Our recommended procedure will assure you of securing the superb performance for which your Stereo Cassette Recorder was designed.

For convenience, this manual is divided into two parts. The first part outlines a simplified operating procedure. The second part provides a more detailed description of the features of your Stereo Cassette Recorder, and explains some of the finer points of recording techniques.

For quick identification of the many controls, connection facilities, and adjustments on your unit, all references to them in this manual are printed in **BOLDFACE** type.

## AFTER UNPACKING

It is advisable to retain all original packing material to prevent damage should you wish to transport your Unit (refer to page 11 for Repacking and Shipping instructions). Be careful that you do not inadvertently throw away or lose the parts packed with the unit. Please inspect your Stereo Cassette Recorder carefully. Our very strict quality control and professional pride ensure that each unit leaves the factory in perfect condition. If the unit is damaged or fails to operate, immediately notify your dealer. If the unit was shipped to you directly, notify the transportation company without delay. Only you, the consignee, may institute a claim against the carrier for shipping damage. Save the carton and all packing material as evidence of damage for their inspection. Should assistance be required, the Marantz Company will cooperate fully in assisting your claim.

### PURCHASER'S RECORD

MODEL NO. \_\_\_\_\_  
(Located on Front of Unit)

SERIAL NO. \_\_\_\_\_  
(Located on Rear of Unit)

Cost \_\_\_\_\_ Date \_\_\_\_\_

This information becomes your permanent record of a valuable purchase. It should be filled in promptly then kept in a safe place along with your purchase receipt to be referred to as necessary for insurance purposes or when corresponding with Marantz.

### IMPORTANT

WHEN SEEKING WARRANTY SERVICE, IT IS THE RESPONSIBILITY OF THE CONSUMER TO ESTABLISH PROOF AND DATE OF PURCHASE. (YOUR PURCHASE RECEIPT OR INVOICE IS ADEQUATE FOR SUCH PROOF.)

## QUICK REFERENCE INDEX

The drawings in Figure 1, provide a reference number for each of the panel features. These numbers reference a descriptive paragraph about the feature and may be located in the PANEL FEATURES section.

Before operating your new unit, take a few moments to acquaint yourself with some of the features and terminology you will encounter in this book.

## PANEL FEATURES

- ① **SPEAKER**
- ② **CASSETTE COMPARTMENT**
- ③ **TAPE COUNTER**

Used for easy reference and indexing. To return the numbers to "000" depress the RESET button.

- ④ **TAPE SELECTOR**

Selects the proper bias and equalization to suit the most common types of cassette tapes.

NORM — for normal ferric oxide tapes.

CrO<sub>2</sub> — for chromium dioxide and other tapes requiring 70  $\mu$ S equalization and high bias.

METAL — for metal tapes

- ⑤ **NOISE REDUCTION SWITCH (PMD430 only)**

This switch is used to select the noise reduction system (Dolby NR, dbx, or NR OFF). (See page 8.)

- ⑥ **DOLBY NR / MPX FILTER SWITCH (PMD420 only)**

Activates the built-in Dolby Noise Reduction circuitry during recording and playback. (See page 9.)

- ⑦ **STOP/EJECT BUTTON**

The STOP/EJECT Button serves a dual purpose. To stop the tape in any mode, depress the button lightly. To open the cassette compartment lid, release the button and depress again firmly.

- ⑧ **PLAY BUTTON**

When depressed, the PLAY Button engages the playback circuitry for flawless reproduction of previously recorded tapes.

- ⑨ **FAST FORWARD/CUE BUTTON (FF/CUE)**

Depress this button for rapid advancement to any desired point on the tape. If depressed during playback, the tape will advance until the button is released, at which point tape play resumes automatically.

- ⑩ **REWIND/REVIEW BUTTON (REW/REVIEW)**

Depress this button to rapidly rewind a tape. If depressed during playback, the tape will rewind until the button is released, at which point tape play resumes automatically.

## 11 RECORD BUTTON (REC)

Press this button together with the **PLAY** button to begin recording.

## 12 PAUSE BUTTON

To stop a tape in Play or Record modes.

## 13 RECORD LEVEL CONTROLS

To increase the recording levels, turn the knob to the right.

## 14 REC INDICATOR

When your unit is in the record mode, the **REC** indicator will light up in red.

## 15 PEAK LEVEL INDICATOR

During recording, the red LED indicates high level transient sounds which are too brief to be measured by the VU Meter.

## 16 MPX FILTER (PMD430 only)

When recording FM stereo broadcasts, the **MPX** filter removes spurious signals which interfere with the Dolby NR system. (See page 8.)

## 17 MEMORY REW

When the tape is rewound with the **MEMORY REW** switch set to **ON**, tape travel stops when the counter reaches "999".

## 18 BIAS FINE ADJUSTMENT

The **BIAS FINE** control enables fine adjustment of the bias to achieve the maximum performance obtainable from the tape used. In most instances the center detented position provides satisfactory biasing for each tape formulation (Normal, CrO<sub>2</sub>, and metal). Tape tolerances may require a slightly different bias.

To adjust the **BIAS FINE** control for optimum performance proceed as follows:

Connect the PMD430 line in and line out to your amplifier as indicated in No. 28 and 29. When recording from a program source with exceptional high end response, listen to the results during recording and compare the sound quality between source and tape. Adjust the **BIAS FINE** control for the best results.

## 19 PITCH CONTROL

When the **PITCH CONTROL** knob is at the "0" position, it is set at normal speed. Turn it in the H direction to increase the tape speed. Turn it in the L direction to decrease the tape speed.

## 20 VU METERS

The VU Meters indicate the average Record/Playback level.

## 21 BATT/LIGHT BUTTON

Pressing this button while the recorder is operating lights the two VU Meters. The meter lamps go out approximately 10 seconds after the button is released. The meter on the left indicates the battery condition when this button is depressed.

## 22 LIMITER

When this switch is set to **ON**, strong signals will be automatically limited assuring low distortion recording. Be sure to set this switch to **OFF** when adjusting the recording level. The **LIMITER** has no function during playback.

## 23 MONITOR SWITCH (PMD430 only)

When recording, this switch may be placed in the **SOURCE** position to monitor the signal before it is recorded, or the **TAPE** position to monitor the signal actually recorded on the tape. (See page 7.)

## 24 VOLUME CONTROL

The **VOLUME** Control regulates the sound volume heard through the speaker(s) and headphones.

## 25 PHONES JACK

Accepts headphones (optional) utilizing a standard stereo phone plug.

## 26 MICROPHONE ATTENUATOR SWITCH

For extremely loud volume microphone recordings, depressing this switch prevents input overload and better record level adjustment.

## 27 MICROPHONE JACKS

Will accept any low impedance microphone (optional) utilizing a standard 6 mm phone plug. When using stereo microphones which use one plug for both the left and right channels (optional), insert that plug into the L (STEREO) jack.

### NOTE:

**When microphones are selected for recording do not monitor through speakers as this will cause howling (acoustic feedback) which could damage your audio equipment. Use headphones for monitoring.**

## 28 LINE INPUT

Should be connected to the Tape output jacks of your amplifier.

## 29 LINE OUTPUT

Should be connected to the Tape Monitor inputs of your amplifier.

## 30 DIN JACK

The connection of a DIN cable between this jack and the DIN jack of an external component, duplicates both **LINE OUTPUT** and **LINE INPUT** functions.

## 31 SPEAKER ON/OFF SWITCH (SPKR MON)

Place this switch in the **ON** position to monitor recordings through the built-in speaker.

## 32 SPEAKER MODE SWITCH (SPKR MODE)

Select Left, Right or Left + Right channels for speaker monitoring.

## 33 SHOULDER STRAP

## 34 EXTERNAL DC POWER INPUT JACK (DC 4.5 V)

This jack is provided to operate your stereo cassette recorder from an external 4.5 volt DC power source.

## 35 BATTERY COMPARTMENT

Accepts three "D" size batteries or the MARANTZ Rechargeable Battery Pack (RB430).

## 36 MIC MODE SWITCH

This switch should be used for monaural recording when a microphone is used. When this switch is in the **MONO** position, it is possible to record with the microphone connected to the **STEREO/L** jack.

For the **STEREO** position of this switch, please refer to the paragraph explaining the use of microphones.

When the switch is in the **MONO** position, the **R** mic is disabled.

## POWER SOURCES

Your Stereo Cassette Recorder may be operated using any of three power sources:

### BATTERY OPERATION (BATTERIES NOT INCLUDED)

- Open the Battery Compartment cover by depressing the finger grip and pulling OUT (See Figure 3 on Page 20).
- Install three "D" size batteries.

### IMPORTANT:

Each battery should be installed observing the correct polarity as shown in Figure 4.

- Close the Battery Compartment cover.

### NOTE:

When checking battery condition, a left meter reading below the "BATT" area indicates a weak battery condition. When this occurs, replace all three batteries.

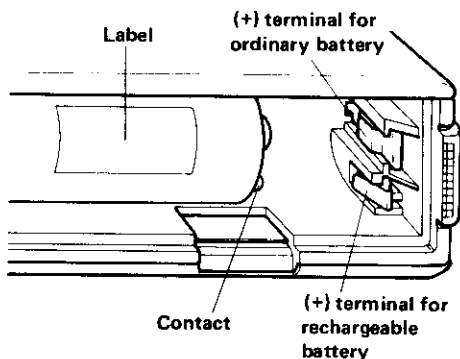

Figure 4.

### RECHARGEABLE BATTERY PACK

The RB430 can be recharged again and again, thereby eliminating the need for frequent battery replacement.

### RECHARGEABLE BATTERY PACK INSTALLATION

Open the battery compartment cover, then install the battery pack by pressing the flat negative (-) side of the pack against the spring and positioning the positive (+) side of the pack against the charging terminal of the recorder. Make sure that the label side of the battery pack is facing up.

### CHARGING THE BATTERY PACK

The battery pack can be charged by connecting the AC adapter. Charge the rechargeable battery RB430 for 16 – 24 hours with the unit stopped. If the battery is charged with the unit operating, it cannot be charged fully.

The RB430 is shipped uncharged, to prevent deterioration during storage. Be sure to charge the battery before use.

## AC POWER

The AC adapter accessory makes it possible to operate the recorder on AC power. Before plugging the adapter into an AC outlet, check the outlet voltage and set the AC adapter for that voltage. Afterwards, insert the AC adapter's output plug into the 4.5V DC jack in the recorder.

### NOTE:

The RB430 Battery Pack is automatically recharged, and the batteries disconnected, when the power cord is connected to the AC receptacle.

### CAUTION:

When not using the recorder, unplug the AC adapter from the wall outlet and the DC jack on the recorder.

### CAUTION FOR RECHARGEABLE BATTERY

It takes approximately 16 to 24 hours to recharge the RB430 Battery Pack. Charging for a longer period of time will overcharge the RB430, and will shorten the life of your battery pack.

The battery can be destroyed if shorting, so be careful to avoid shortage.

### OPERATION DURING CHARGING

It is advisable not to operate the unit during charging as it could cause problems with the AC adaptor.

### CAUTION UPON USING THE AC ADAPTOR

If the AC adaptor is detached from the AC outlet but is still plugged into the PMD420 or PMD430, the unit cannot operate even if power is supplied from another source (batteries for example).

### AC ADAPTOR

The AC adaptor accessory can only be used with the PMD420 or the PMD430. Do not use this AC adaptor for other units as this could cause problems.

### POWER FROM AN EXTERNAL DC SOURCE

This unit can also be operated with an external DC power source of 4.5 V and 700 mA. A "DC to DC" converter must be used to operate the unit with DC power sources other than 4.5 volts, such as a 12 volt automobile battery. DC to DC converters for this purpose may be purchased at many retail electronics stores. To operate this unit, the DC to DC converter must have a plug that will fit the DC 4.5 V Input jack on the side of the unit. This plug must be the same type of coaxial sleeve power plug found on the AC adaptor supplied with your unit. Note that this plug has an outer diameter of 0.217 inch, an inner diameter of 0.080 inch, and a length of 0.375 inch. The converter output must produce 4.5 V DC and 700 mA.

Connect the 4.5 V DC output plug of the DC to DC converter to the DC 4.5 V Input jack on the side of the unit, and follow the DC to DC converter manufacturers' instructions for connection to a 12 V or other power source.

### NOTE:

The outer sleeve of the DC to DC converter plug must be positive (+), and the inner sleeve must be negative (-).

It is very important that any DC to DC converter used with this unit must conform to these specifications, or serious damage to your unit may be caused.

## BATTERY CHECK

When the BATT LIGHT button is pressed, the meter on the left shows the amount of battery wear. The "D" mark on the scale indicates the minimum level on which the unit can be used with dry cells. Change the batteries when the charge falls below this level. The "R" mark indicates the minimum level for the rechargeable battery pack; recharge the battery pack when the meter reads below this level.

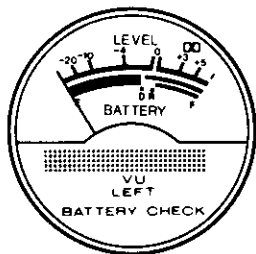

Figure 5.

## OPERATING INSTRUCTIONS

### PRELIMINARY CONTROL SETTINGS

Rec Level (L/R)	Minimum (to left)
Volume	Minimum (to left)
Monitor (PMD430 only)	Source
Tape Select	Set EQ and BIAS to match the type of tape you are using
<b>NOISE REDUCTION LIMITER</b>	OFF
<b>SPKR MON</b>	OFF
<b>SPKR MODE</b>	ON
<b>MIC ATT</b>	L + R
	0 dB

### RECORDING CONNECTIONS

You may record through the Microphone or Line Input jacks.

For microphone recording, connect an optional low impedance One-Point Stereo Microphone or two optional individual microphones to the **MIC L** and **R** jacks of your cassette recorder. Please note that only microphones which employ a 6 mm phone plug may be used.

The Line Input jacks are used to record line level signals from an external source such as a receiver or another tape recorder. Connect one end of an audio cable (with a phono plug termination) to the **L LINE IN** jack of your cassette recorder, and the other end of the cable (terminated with an appropriate plug) to the Left channel output jack of the external source. Connect your cassette recorder's **R LINE IN** jack to the Right channel of the external source in the same manner.

#### NOTE:

When using a one-plug type stereo microphone, insert the plug in the **L (STEREO)** jack.

### TO RECORD

1. Insert a blank cassette.
2. Push the **REC** button and the **PLAY** button together.

Your Stereo Cassette Recorder is now in the Record mode.

## TYPE AND BRAND OF TAPES TO USE

In cassette recording, the type and brand of cassette you use has a great influence on the quality of your recordings. Therefore, it is advantageous to purchase the highest quality cassettes available. Chromium dioxide (CrO<sub>2</sub>) and metal tapes generally provide better fidelity than normal ferric oxide tapes. When using these kinds of tapes, set the **TAPE SELECTOR** switch on the unit in the correct position to suit the characteristics of the tape.

We recommend the use of cassettes with a recording capacity of 90 minutes or less.

We can assure quality performance of our tape decks using tape selected from the following table.

NORMAL	BASF	Performance Series
	FUJI	Studio Series
	MAXELL	Professional I
	MEMOREX	FX-1
CrO <sub>2</sub>	SCOTCH	FL
	SONY	LN
	TDK	UD-XL 1
		UD
METAL		MRX <sub>3</sub>
		Master I
		Dynarange
		Highlander
		Low Noise
		High Fidelity
		AD Series
		D
		M
		Professional II
		Chromium Dioxide
		FX-11
		UD-XL11
		High Bias
		Master II
		Chrome
		SA Series
		Metafine
		MA Series

### MONITORING DURING RECORDING

#### SOURCE MONITORING (PMD430 only)

With the **MONITOR** Switch in the **SOURCE** position and the **SPKR MON** switched **ON**, you will be able to monitor the source being recorded by simply turning up the **VOLUME** Control.

#### SOURCE MONITORING (PMD420 only)

With the **SPKR MON** switched **ON**, you will be able to monitor the source being recorded by simple turning up the **Volume** Control. Monitoring may be accomplished through the use of the internal speaker, or a stereo headphone.

The **SPKR MODE** preliminary control setting given is for monitoring through the internal speaker.

When monitoring the recording with headphones, place the **SPKR MODE** switch in the center (L&R) position.

## TAPE MONITORING (PMD430 only)

In addition to source monitoring, the PMD430 contains a third head which enables you to monitor directly from the tape as a recording is made. To use this feature, place the MONITOR Switch in the TAPE position and turn up the VOLUME Control.

Source and Tape Monitoring may be accomplished through the use of the internal speaker, line output connections or a stereo headphone.

The SPKR MODE preliminary control setting given is for monitoring through the internal speaker.

### NOTE:

Refer to Page 9 for instructions on how to monitor Dolby NR recordings.

It takes about 1 second to start recording after the PLAY or RECORD button is pressed. To start operation immediately, press the PAUSE button, then the PLAY or RECORD button, and the PAUSE button again.

### CAUTION:

To avoid audio feedback when making a microphone recording, place the microphones a suitable distance away from the speaker. If desired, the internal speaker may be defeated by placing the SPKR MON Switch to the OFF position.

## ADVANCED RECORDING TECHNIQUES

### CONTROLLING THE RECORD LEVEL

The best method of controlling the record level is determined by the content of the particular program source. Use the guidelines below to obtain the desired recording results.

### LIMITER

**ON:** Allows you to manually set the recording level of both channels using the Rec Level Controls while an internal limiter circuit automatically prevents overload distortion resulting from sudden level peaks.

**OFF:** Permits full manual control of the recording level of both channels using the Rec Level Controls. This position assures optimum dynamic range recordings.

## SETTING THE RECORD LEVEL

### PROCEDURES FOR RECORDING WITH THE LIMITER

Turn the limiter on after setting the recording level. To set the level, set the limiter switch to OFF, then adjust the REC VOLUME control while watching the VU meters.

Ordinarily, VU meter needle deflection should be as large as possible, while the peak level meter should only light up occasionally. If the indicator lights continuously, the level is too high; this will result in distorted sound. Conversely, if the VU meter needle stays on the left side of the scale and the indicator does not light at all, the level is too low and a poor S/N ratio will result.

## HIGH VOLUME MICROPHONE RECORDINGS

Certain microphone recording situations may result in extremely high microphone input levels. In such cases the Rec Level Control cannot be set to the desired position without VU meter deflection far into the red zone. A greater range of Record Level Control rotation can be obtained by depressing the MIC ATT Switch. When depressed, this switch will attenuate the input level by 15 dB or 30 dB. In normal recording, leave the MIC ATT Switch in the "out" position or "0".

## NOISE REDUCTION SYSTEMS

### dbx Noise Reduction System (PMD430 only)

The dbx NR system provides a large noise reduction effect resulting in wide dynamic recording. The dbx NR system has the following features:

1. The noise reduction effect is about 30 dB in the absence of a signal.
2. The dbx works linearly on the whole audio band to obtain a wide band noise reduction effect.
3. The sound should not distort even at high recording levels.
4. The maximum recording level at high frequency is increased.
5. Low distortion recording is possible, resulting in real hi-fi sound.
6. Level matching is not necessary, resulting in small tracking error between recording and playback.

### Recording/playback with dbx NR system

The PMD430 NR switches are located as shown in the Figure 6.

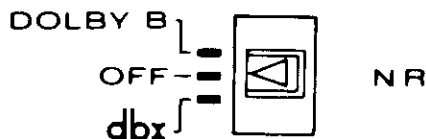

Figure 6.

"dbx" . . . . . When the NR switch is set to dbx, recording and playback using the dbx NR system are possible.

"dbx encoded disk" . . . To record a dbx encoded disk, set the NR switch to OFF. To playback the recorded tape, set the Noise Reduction switch to dbx.

### DOLBY B NR SYSTEM

The Dolby B Noise Reduction system increases the level of low volume, mid and high frequency signals during recording and reduces the level of these signals by an identical amount during playback. As a result the playback signal is identical to the original source signal but the level of background noise generated by the tape and tape recorder is reduced.

### Recording/Playback with Dolby B NR system

For recording and playback with the Dolby noise reduction system set the NOISE REDUCTION switch to DOLBY B NR.

### MPX FILTER (PMD430 only)

When recording FM stereo with the Dolby NR system, set the MPX FILTER switch to ON. When recording from other sources or without Dolby NR, set the MPX FILTER switch to OFF.



## DOLBY B TYPE NR (PMD420 only)

The PMD420 NR switches are located as shown in the figure below.

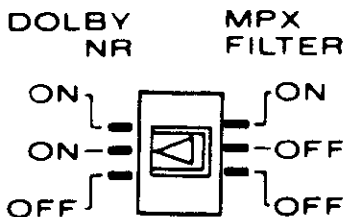

Figure 7.

Set the **NOISE REDUCTION** switch to **ON** when using Dolby noise reduction. This enables both Dolby NR recording/playback. When recording stereo broadcasts with Dolby NR, set **DOLBY NR** and **MPX FILTER** to **ON**. Otherwise, set **DOLBY NR** to **ON** and **MPX FILTER** to **OFF**.

**"NR OFF"** . . . . . To turn the NR circuit OFF, set the NR switch OFF. On this setting, recording/playback without NR system is possible.

As NR systems are not interchangeable, play back the tape with the NR system used to record it.

## MONITORING YOUR RECORDING (PMD430 only)

The Double Dolby NR system used in the PMD430 enables you to encode and record a signal using the Dolby NR process and at the same time to decode and monitor that signal from the tape. The decoded signal may be monitored when the **MONITOR** Switch is placed in the **TAPE** position.

### NOTE:

When playing back a tape recorded with Dolby NR, always place the **NOISE REDUCTION** Switch to the Dolby NR position.

### IMPORTANT:

In the Record mode, previously recorded information on the tape will automatically be erased.

## TO PROTECT VALUABLE RECORDINGS

You can prevent your valuable recordings from being erased by removing the safety tabs on your cassette tape. Use a small screwdriver to breakout one or both safety tabs. (Figure 8 on Page 20 shows how to remove the side "A" safety tab.)

The record capability of either side of a cassette can be restored by covering the appropriate opening where the tab was removed with cellophane tape. (Figure 9 on Page 20 shows cellophane tape applied to side "A" safety tab opening.)

## TO PLAYBACK

1. Insert a pre-recorded cassette, or playback a tape just recorded—rewind the tape to the beginning.
2. Be sure the EQ setting of the Tape Select Switch matches the type of tape you are using.
  - METAL 70  $\mu$ S
  - SPECIAL CrO<sub>2</sub> 70  $\mu$ S
  - NORMAL 120  $\mu$ S
3. Place the **MONITOR** Switch in the **TAPE** position (PMD430 only).
4. Set the **NR** Switch to **OFF** when playing back a tape recorded without NR system. Set the **NR** Switch to **Dolby B NR (PMD420)** or to **Dolby B NR (PMD430)** when playing back a tape recorded with Dolby B NR. Set the **NR** Switch to **dbx (PMD 430)** when playing back a tape recorded with dbx NR system.
5. Depress the **PLAY** Button.
6. Adjust the Volume Control for a comfortable listening level.

### NOTE:

For playback through optional headphones, or Line Output connections, refer to the **SPECIAL FEATURES SECTION**.

## REWIND

Check that the **MEMORY REW** switch is in the **OFF** position. To rewind a tape, depress the **REW/REVIEW** Button. The tape will rewind to the beginning. To stop at other desired points, depress the **STOP/EJECT** Button.

## REVIEW

Check that the **MEMORY REWIND** switch is in **OFF** position. Partially depressing the **REW/REVIEW** Button during Playback operation permits you to monitor information on the tape as it rewinds. When fully depressed, information is muted. When the desired portion of the tape is reached, release the button to automatically resume tape play.

## FAST FORWARD

To rapidly advance the tape in a forward direction, depress the **FF/CUE** Button. when the desired point is reached, depress the **STOP/EJECT** Button.

## CUE

Check that the **MEMORY REW** switch is in the **OFF** position. Partially depressing the **FF/CUE** Button during Playback operation permits you to monitor information on the tape as it is rapidly advanced. When fully depressed, information is muted. When the desired portion of the tape is reached, release the button to automatically resume tape play.

## PAUSE

Depress the **PAUSE** Button to momentarily stop the tape in the Record or Playback modes. Depress the button a second time to resume tape motion.

The Pause feature provides for the convenient editing of material while recording, or the playback of individual short segments of tape while remaining in the selected mode of operation.

**CAUTION:**

The **FAST FORWARD** and **REWIND** buttons will not lock down if no battery or AC power is supplied. This is not an indication of trouble with the unit.

With the **MEMORY REWIND** switch set to **ON**, the **REW** and **FF** button cannot be locked when the tape counter reads 900~999.

**PITCH CONTROL**

The **PITCH** control operates only during playback. Note that variations in the frequency response increases during playback for tapes recorded using noise reduction. Normal speed is indicated when the **PITCH** control is set to the center (click) position.

**CAUTION:**

- When recording using a microphone, howling may result with the **SPEAKER** switch set to **ON**. At that time, use headphones or set the **SPEAKER** switch to **OFF**.
- At the beginning or the end of a recording, popping noises are sometimes recorded on the tape. To prevent this, proceed as follows.
  1. Press the **PAUSE** button.
  2. Press the **RECORD** and **PLAY** buttons.
  3. Press the **PAUSE** button again to start recording.
  4. Press the **PAUSE** button to stop the tape.
  5. Press the **STOP** button to stop recording.
- When recording with batteries, using the speaker or headphones to monitor may exhaust the batteries. Set the monitor control to zero except when necessary.
- When the batteries are exhausted, the tape moves, but recording is sometimes not possible. Refer to the battery indicator to see if your batteries need to be replaced.
- When the unit is used at low temperatures, the power consumption of the unit increases and the battery voltage decreases. In low temperatures, the battery life may be shortened.

**SHOULDER STRAP**

The adjustable shoulder strap provides a convenient method for carrying your cassette recorder during mobile operation.

**Attaching the Shoulder Strap**

Figure 10.

**SPECIAL FEATURES****USE OF A HEADPHONE**

For private listening, connect a low impedance headphone (optional) incorporating a 6 mm stereo phone plug to the **PHONES** jack. When monitoring a stereo recording, set the **SPKR MODE** switch to the (L+R) position.

**LINE OUTPUT CONNECTIONS**

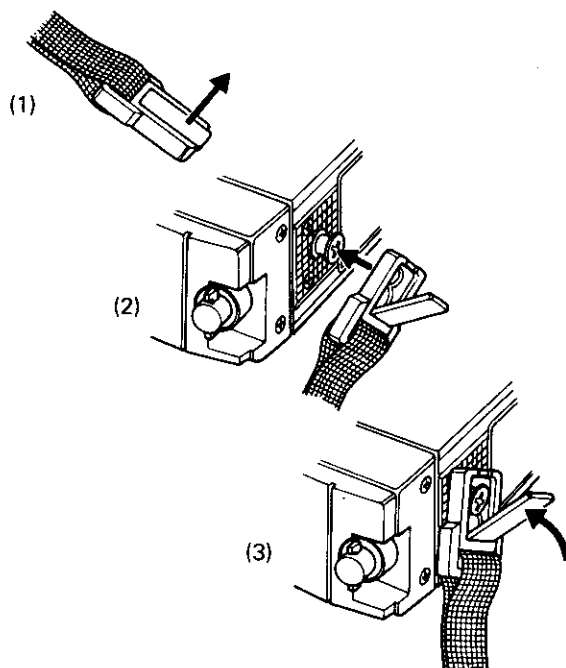
An external component may be connected to these jacks to monitor or record from your cassette recorder.

**TOTAL SHUT OFF**

This built-in feature automatically disengages the transport and shuts off the unit when the end of the tape is reached in any mode of operation.

**AUTO REPLAY**

When the **REW** button is pressed and locked while the unit is in the **PLAY** mode with the **MEMORY REW** switch set to **ON**, the tape is rewound until the counter reaches "999": tape travel then automatically starts in the **PLAY** mode. Playback can be started at any point desired by zeroing the counter at that point in advance.

**MEMORY REW**

When the **REW** button is pressed with the **MEMORY REW** switch set to **ON**, tape travel stops when the counter reaches "999". Playback can be started at any point desired by zeroing the counter at that point in advance.

**TO ERASE A TAPE**

1. Insert the cassette with the side you wish to erase facing UP.
2. Set the **REC VOLUME** to minimum (fully counterclockwise).
3. Simultaneously press the **REC** and **PLAY** buttons.

**USE OF THE DIN JACK**

The **REC/PLAY** jack is a **DIN**-type jack which permits your unit, through the use of a European 5-wire cable, to record from or playback through similarly equipped external components.